

FWS VERSION - ROLLER BEARINGS - 1750 RPM

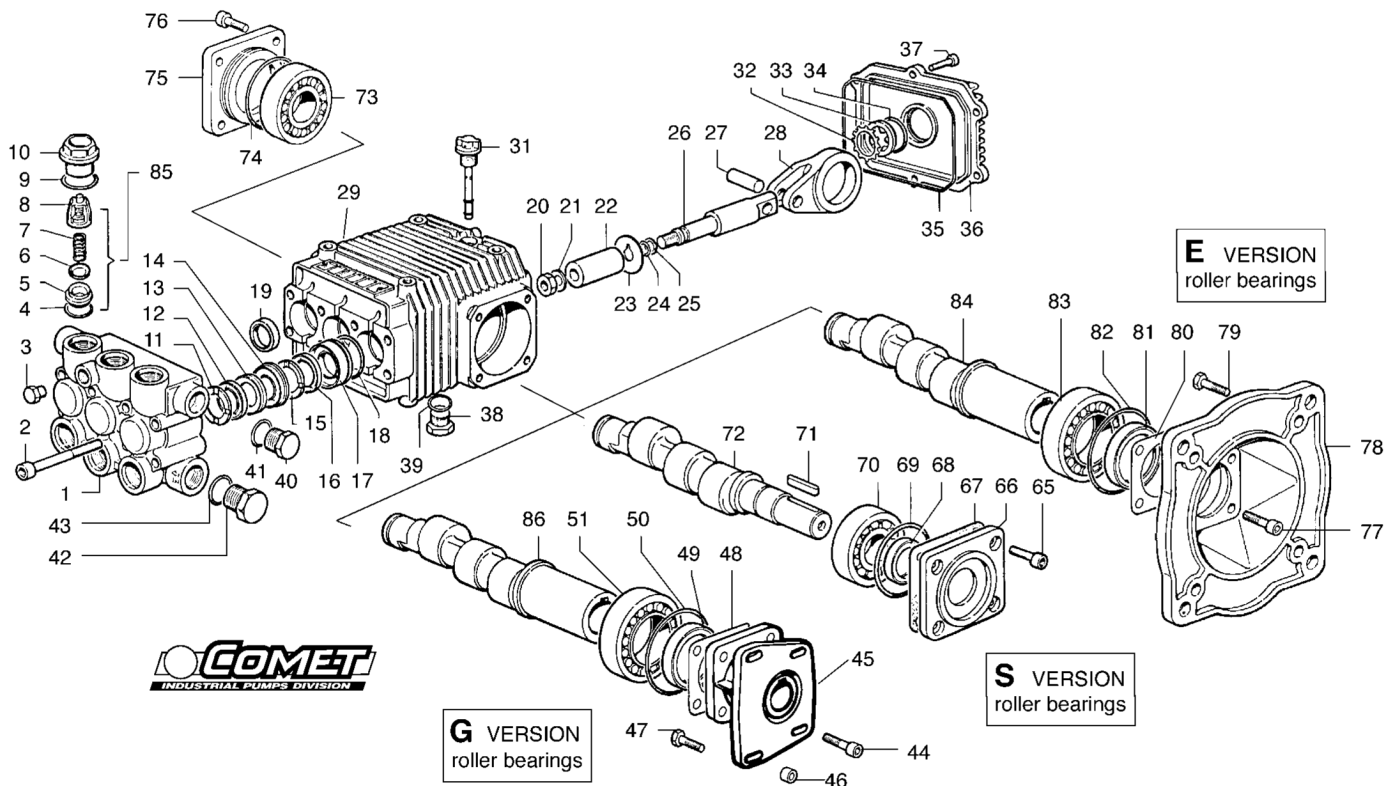

ITEM	PART No.	KIT	DESCRIPTION	Qty.	MODELS
1	3218.0109.00		MANIFOLD Ø 20 mm	1	5520 S - 5525 S 6020 S - 5530 E
	3218.0110.00		MANIFOLD Ø 18 mm	1	3530 S - 3530 E 4030 S - 4030 E 4030 G - 4525 S 4530 S - 4530 E
2	3609.0039.00		SCREW M8X70	8	
3	3202.0112.00		CAP G1/4"	1	
4	1210.0046.00	A-D	O-RING 2,62X 17,13 mm	6	
5	3009.0087.00	A	VALVE SEAT	6	
6	3604.0017.00	A	VALVE PLATE	6	
7	1802.0177.00	A	SPRING	6	
8	1205.0025.00	A	VALVE CAGE	6	
9	1210.0048.00	A-D	O-RING 2,62X 20,24 mm	6	
10	3202.0155.00		CAP	6	
11	0009.0108.00	B	HEAD RING Ø20 mm	3	5520 S - 5525 S 6020 S - 5530 E
	0009.0199.00	B	HEAD RING Ø18 mm	3	3530 S - 3530 E 4030 S - 4030 E 4030 G - 4525 S 4530 S - 4530 E
12	1241.0032.00	B	PACKING Ø 20 mm	3	5520 S - 5525 S 6020 S - 5530 E
	1241.0026.00	B	PACKING Ø 18 mm	3	3530 S - 3530 E 4030 S - 4030 E 4030 G - 4525 S 4530 S - 4530 E
13	0009.0100.00	B	PACKING Ø18 mm	3	3530 S - 3530 E 4030 S - 4030 E 4030 G - 4525 S 4530 S - 4530 E
	0009.0104.00	B	PACKING Ø20 mm	3	5520 S - 5525 S 6020 S - 5530 E
14	0009.0114.00		INTERMED. RING Ø 20 mm	3	5520 S - 5525 S 6020 S - 5530 E
	0009.0200.00		INTERMED. RING Ø 18 mm	3	3530 S - 3530 E 4030 S - 4030 E 4030 G - 4525 S 4530 S - 4530 E
15	0009.0108.00	B	HEAD RING Ø 20 mm	3	5520 S - 5525 S 6020 S - 5530 E
	0009.0199.00	B	HEAD RING Ø 18 mm	3	3530 S - 3530 E 4030 S - 4030 E 4030 G - 4525 S 4530 S - 4530 E
16	1241.0032.00	B	PACKING Ø 20 mm	3	5520 S - 5525 S 6020 S - 5530 E
	1241.0026.00	B	PACKING Ø 18 mm	3	3530 S - 3530 E 4030 S - 4030 E 4030 G - 4525 S 4530 S - 4530 E

ITEM	PART No.	KIT	DESCRIPTION	Qty.	MODELS
17	0009.0102.00		PACKING RETAINER Ø18 mm	3	3530 S - 3530 E 4030 S - 4030 E 4030 G - 4525 S 4530 S - 4530 E
	0009.0106.00		PACKING RETAINER Ø20 mm	3	5520 S - 5525 S 6020 S - 5530 E
18	1210.0156.00	B-D	O-RING 1,78X31,47 mm	3	
19	0019.0066.00	D	OIL SEAL 20X30X5 mm	3	
20	0600.0054.00	C	NUT	3	
21	2811.0082.00	C	WASHER 8,2X17X1,5 mm	3	
22	0202.0022.00	C	PISTON Ø18 mm	3	3530 S - 3530 E 4030 S - 4030 E 4030 G - 4525 S 4530 S - 4530 E
	0202.0024.00	C	PISTON Ø20 mm	3	5520 S - 5525 S 6020 S - 5530 E
23	2812.0042.00	C	WASHER	3	
24	1210.0039.00	C-D	O-RING 1,78X 7,66 mm	3	
25	0009.0170.00	C-D	ANTI-EXTR. RING	3	
26	2409.0048.00		PISTON GUIDES	3	
27	3011.0016.00		WRIST. PIN Ø10X29 mm	3	
28	0205.0044.00		CON. ROD	3	
29	0403.0129.00		CRANKCASE	1	3530 S - 4030 S 4525 S - 4530 S 5520 S - 5525 S 6020 S
	0403.0130.00		CRANKCASE	1	3530 E - 4030 E 4030 G - 4530 E 5530 E
31	3200.0051.00		OIL DIPSTICK	1	
32	3019.0033.00		SNAP RING Ø18 mm	1	
33	3201.0012.00		OIL INDICATOR	1	
34	1210.0333.00	D	O-RING 1,78X23,52 mm	1	
35	1210.0216.00	D	O-RING 2,62X107,62 mm	1	
36	0402.0169.00		CRANKCASE COVER	1	
37	3609.0030.00		SCREW M5X20	6	
38	3200.0007.00		CAP 3/8 GAS	1	
39	1210.0093.00	D	O-RING 1,78X 14 mm	1	
40	3200.0007.00		CAP 3/8 GAS	1	
41	2811.0084.00		WASHER 16,7X22X1,5 mm	1	
42	3202.0015.00		CAP G1/2	1	
43	2811.0086.00		WASHER 21,2X27X1,5 mm	1	
44	0440.0012.00		ROLLER BEARING	1	
45	1210.0388.00	D	O-RING	1	
46	0402.0171.00		FLANGE	1	
47	3609.0032.00		SCREW M6X20	4	
48	1220.0030.00		VALVE ASS. BLY.	6	